

QUICK INSTALLATION GUIDE <G065-8610>

Please read the Safety Information in the Setup Guide before using this machine. It contains important information related to USER SAFETY and PREVENTING EQUIPMENT PROBLEMS.

1

UNPACKING THE PRINTER AND CHECKING THE CONTENTS OF THE BOX

⚠ Caution

- To prevent injuries, this printer should be lifted by at least two people.

- Check the contents of the box using the following list. If one or more items are missing, please contact your sales or service representative.

⚠ Important

- The interface cable is not supplied in the box. It is your responsibility to provide the interface cable appropriate for the computer that you are using.
- The toner bottle is not included in the box. Consult your sales or service representative about the toner bottle.
- You will need the paper sensor if you install the Bridge Unit Type 450. It is recommended that you keep the paper sensor for future use.
- Quick Installation Guide (this sheet)
- Setup Guide
- CD-ROMs (2)
- Ferrite Core
- Additional Documentation
- Paper Sensor

- Remove the adhesive tape from the printer as shown in the illustration.

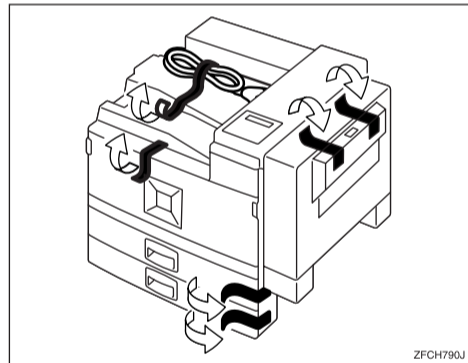

- Open the bypass tray (1), and then open the duplex unit by pushing the catch upwards (2).

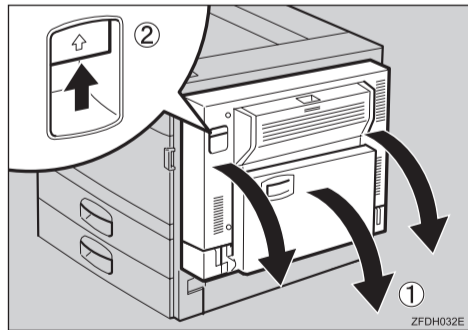

- Remove the packing material as shown in the illustration.

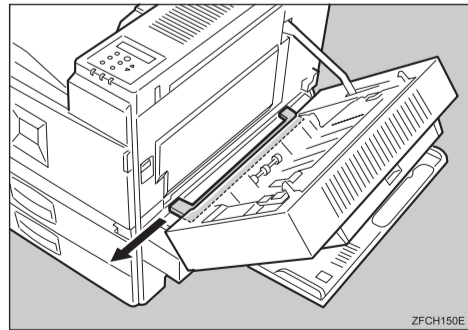

- Open the right cover by pushing the catch upwards.

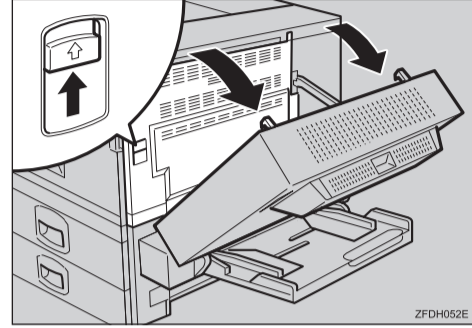

- There is a red plastic wedge with a red tag attached to it. Remove the wedge from the transfer unit.

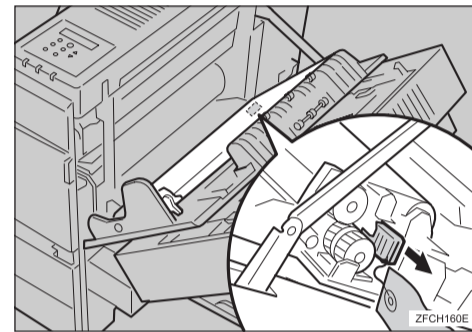

- Close the right cover, the duplex unit and the bypass tray.

- Slide a paper tray out and remove the packing material. Repeat these steps for all paper trays.

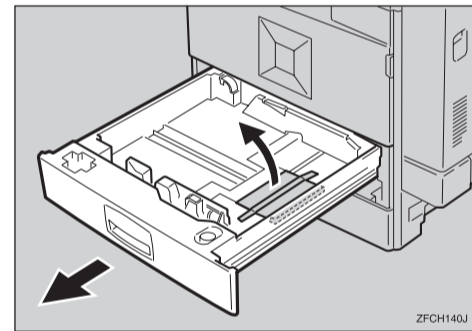

- Remove the two red stoppers that hold the grips in place, and then pull out the grips from the front side of the printer.

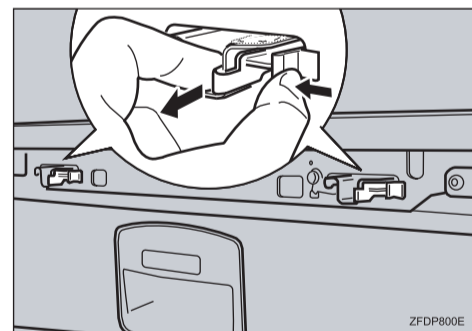

- Lift the printer and move it to the place where you want to install it. When lifting the printer, use the pullout grips on the front side and the inset grips on the rear side. After that, push the grips into the printer.

⚠ Important

- The printer should be held by at least two people.

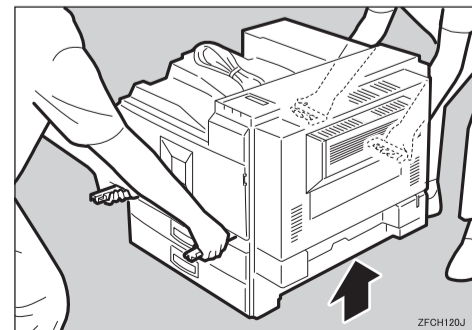

- Take out the cover inside Tray 2 and attach it between the paper tray and the front cover.

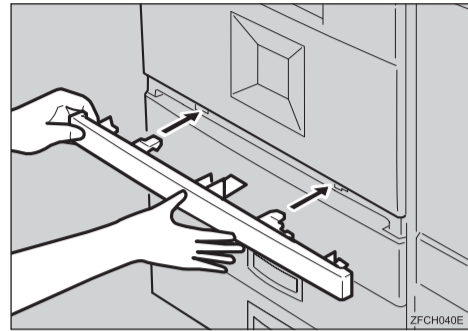

To install the paper bank PS430, see "Installing the Paper Bank PS430" in the Setup Guide.

2

WHERE TO PUT YOUR PRINTER

- Your printer's location should be carefully chosen because environmental conditions greatly affect its performance.

⚠ Warning

- Confirm that the wall outlet is near the machine and freely accessible, so that in the event of an emergency, it can be easily unplugged.
- Only connect the machine to the power source described on this sheet.
- Avoid multi-wiring.
- Do not damage, break or make any modifications to the power cord. Do not place heavy objects on it, pull it hard or bend it more than necessary. These actions could damage the cord. A frayed or damaged cord might cause an electrical and fire hazard.

⚠ Caution

- Do not handle the plug with wet hands. Doing this might cause an electric shock.
- Keep the machine in an area that is within optimum environmental conditions. Operating the machine in an environment that is outside the recommended ranges of humidity and temperature can cause an electrical or fire hazard. Accumulated dust can become an electrical or fire hazard.
- Place the machine on a strong and level surface. Otherwise, the machine might fall and injure someone.
- If you use the machine in a confined space, confirm there is a continuous turnover of air.

Optimum Environmental Conditions

The recommended temperature and humidity

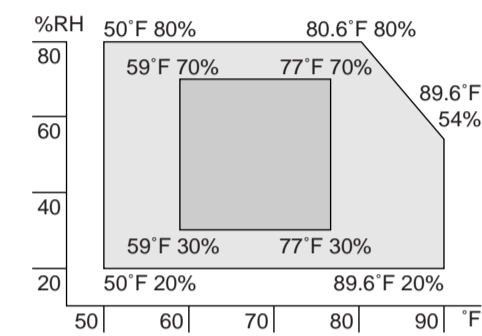
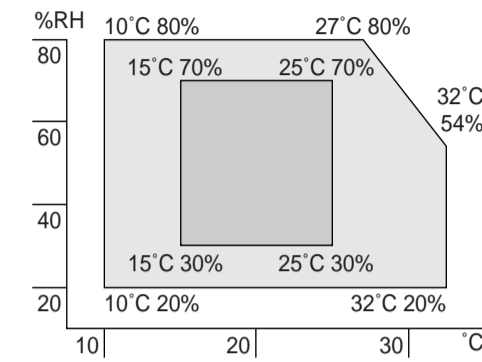

Legend: Possible operation range Recommended range

The printer must be level within 5 mm, 0.2" both front to rear and left to right.

To avoid possible build-up of ozone, locate this printer in a large well ventilated room that has an air turnover more than 30 m³/hr/person.

Space Required for Installing the Printer

Leave enough space around the printer. This space is necessary to operate the printer. The recommended (or minimum) space requirement is as follows:

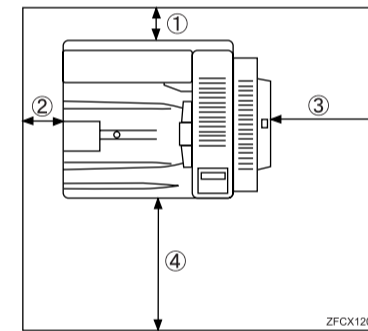

- more than 10 cm (4.0")
- more than 10 cm (4.0")
- more than 40 cm (15.8")
- more than 75 cm (29.6")

- Environment to Avoid

⚠ Important

- Locations exposed to direct sunlight or strong light
- Dusty areas
- Areas with corrosive gases
- Areas excessively cold, hot, or humid
- Locations near an air conditioner or humidifier
- Locations near other electronic equipment
- Locations where the printer might be subjected to frequent strong vibration

- Power Source

Connect the power cord to a power source with the following specifications:

- 220-240 V, 50/60 Hz, 8.0 A or more

3

INSTALLING THE TONER BOTTLE

⚠ Warning

- Do not incinerate toner (used or unused) or toner containers. Toner dust is flammable and might ignite when exposed to an open flame.
- Disposal should take place at an authorized dealer or appropriate collection site.
- If you dispose of the used toner containers yourself, follow local regulations.

⚠ Caution

- The inside of the machine becomes very hot. Do not touch the parts with a label indicating a "hot surface". Touching a "hot surface" could result in a burn injury.
- Do not eat or swallow toner.
- Keep toner (used or unused) and toner containers out of reach of children.
- Our products are engineered to meet the highest standards of quality and functionality. When purchasing expendable supplies, we recommend using only those provided by an authorized dealer.

- Open the front cover.

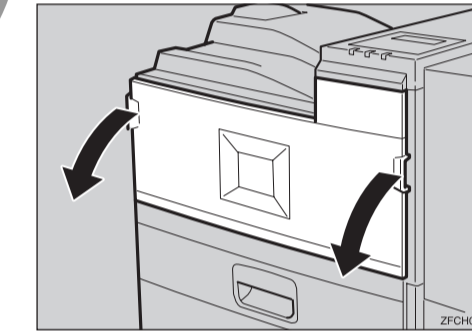

- Remove the tape with the red tag.

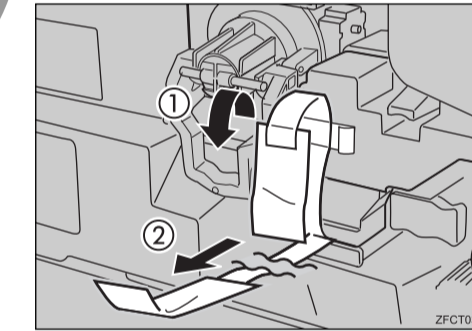

- Lift the green handle.

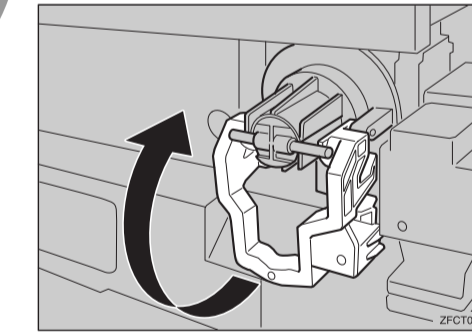

- While pushing the green lever to the right (1), hold the handle and gently slide the toner holder out (2).

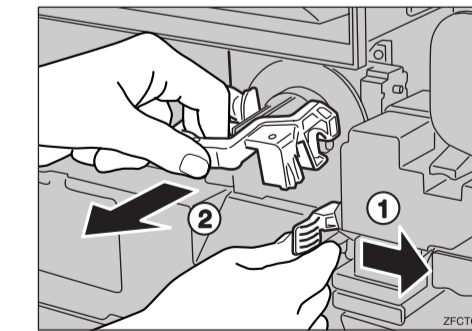

- Move the new toner bottle back and forth about 5 - 6 times as shown in the illustration.

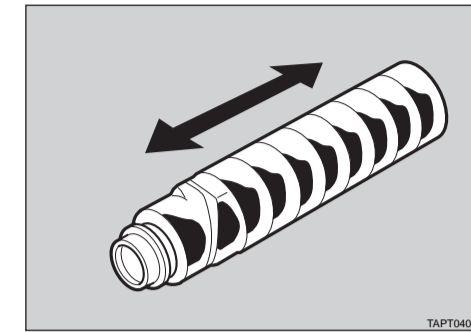

- Remove the black cap of the new toner bottle by turning it counterclockwise.

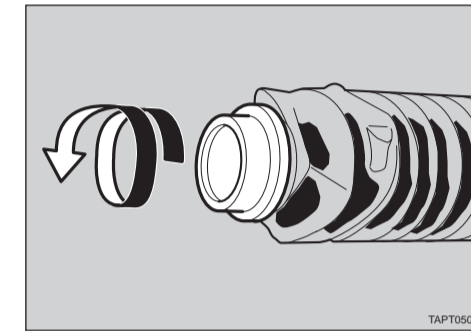

Note

- After removing the black cap from the bottle, toner can scatter easily. Do not shake or jar the bottle.

- Place the toner bottle on the toner holder (1), and then pull its head toward you (2) to lock it in place.

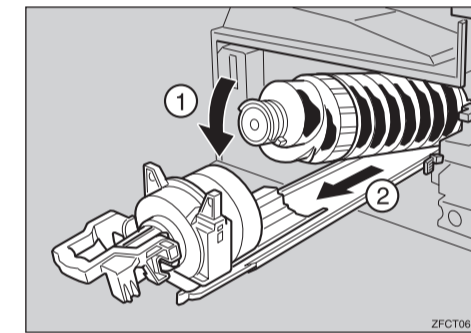

- Slide the toner holder into the printer until it clicks into place (1), and then push down the green handle (2).

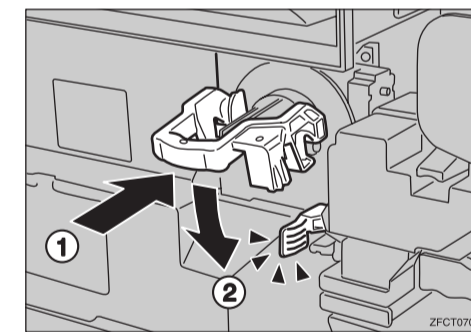

- Close the front cover.

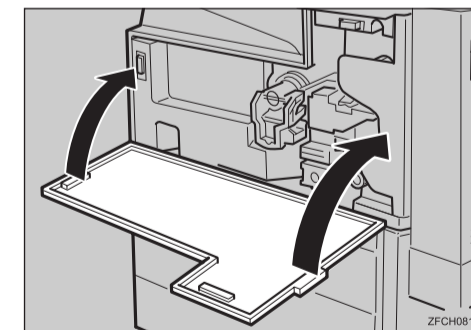

4

INSTALLING THE PAPER TRAY

The default paper settings size are as follows:

- Tray 1
 - Metric version: A4 (long-edge feed)
 - Inch version: 8 1/2" x 11" (long-edge feed)

- Tray 2
 - Metric version: A3 (short-edge feed)
 - Inch version: 11" x 17" (short-edge feed)

For settings other than the default paper size, see "Changing Paper Size of the Paper Tray" in the Setup Guide.

For more information on the paper sizes that can be set in the paper tray, see "Paper and Other Media Supported by Your Printer" in the Setup Guide.

For installing the bypass tray, see "Loading Paper in the Bypass Tray" in the Setup Guide.

- Slide the paper tray out until it stops.

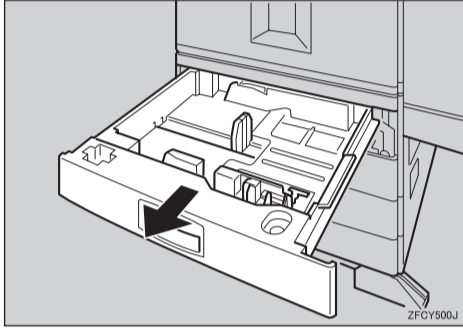

- Pinch the sides of the rear guide (1), and remove it (2).

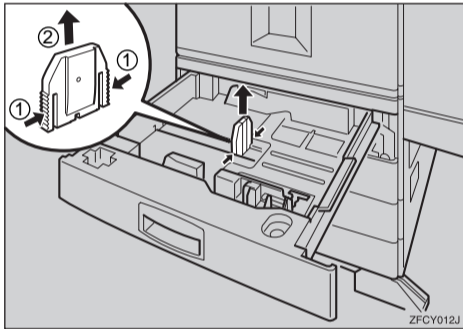

- Align all four sides of the paper stack and load it into the tray.

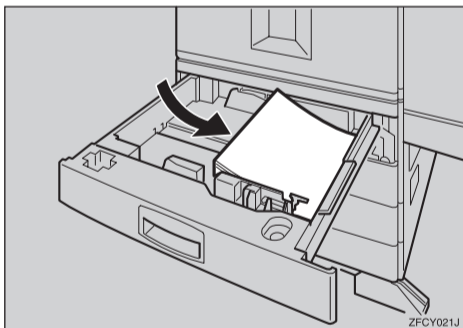

Important

- Confirm that the top of the stack is not higher than the limit mark inside the tray.
- To avoid paper skew, confirm that there is no space between the side guides and the paper.

- While lifting the left side of the paper, attach the rear guide.

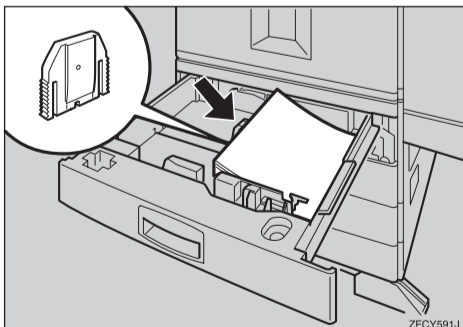

5

Slide the tray into the printer until it stops.

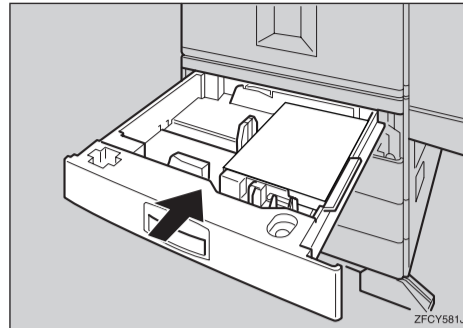

Important

- Be sure to insert the paper tray completely. Otherwise, paper misfeeds might occur, or the front cover might touch the paper tray.

5

CONNECTING THE POWER CORD

Caution

- Do not handle the plug with wet hands. Doing this might cause an electric shock.

- Confirm that the printer power is turned off. If it is on, turn it off.

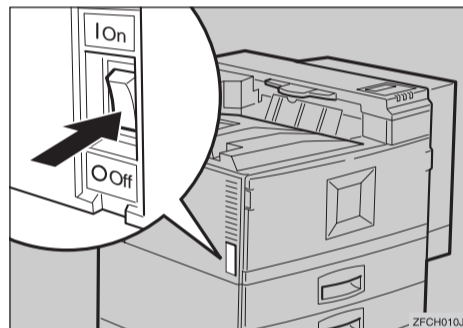

- Insert the plug of the power cord securely into the wall outlet.

6

SELECTING THE PANEL DISPLAY LANGUAGE

Note

- You can select one of the following languages: English, German, French, Italian, Dutch, Swedish, Norwegian, Danish, Spanish, Finnish, Portuguese, Czech, Polish, or Hungarian.
- The default setting is English.
- If you want to use the English panel display, the following procedure is not necessary.
- The first time you turn the printer on after installation or after replacing the photoconductor unit, it will make several loud noises. This is due to the photoconductor unit initializing and is perfectly normal.

- Turn on the printer power.

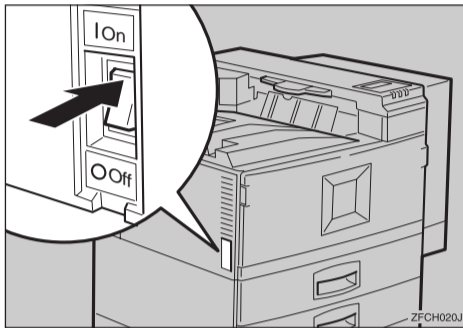

After the printer warms up, the ready message appears on the panel display.

- Press the Menu [] key.

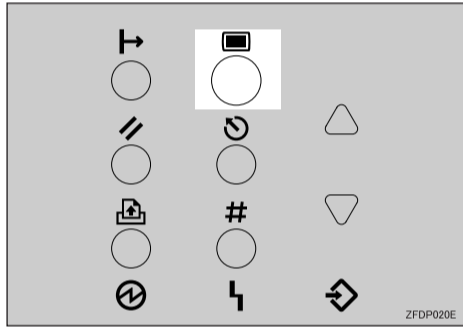

The following message appears on the panel display.

Main Menu:
Sample Print

- Press the [▼] or [▲] key until "Language" appears, and then press the Enter [#] key.

Main Menu:
Language

- Press the [▼] or [▲] key to display the language you want to select, and then press the Enter [#] key.

List Print:
French

The following message appears on the panel display for two seconds, and the panel display automatically returns to the previous menu.

List Print:
*French

- Press the Escape [] key.

7

PRINTING THE TEST PAGE

You can confirm that the printer works properly by printing a test page (configuration page).

However, you cannot check the connection between the printer and your computer by printing the test page.

- Confirm that the printer power is turned on.

- Press the Menu [] key.

The following message appears on the panel display.

Main Menu:
Sample Print

- Press the [▼] or [▲] key until the following message appears on the panel display.

Main Menu:
List/Test Print

- Press the Enter [#] key.

The following message appears on the panel display.

List Print:
Config. Page

- Press the Enter [#] key.

In a short time, the test printing will start.

Important

- If you cannot complete the test printing correctly, check if an error message appeared on the panel display. For more information on error messages, see "Troubleshooting" in the Setup Guide.

8

CONNECTING THE PRINTER

A

Connecting the Printer to the Network

Important

- The network cable is not supplied with the printer. It is your responsibility to get a network cable that is appropriate for the network.
- The printer's network connection is 10BASE-T/100BASE-TX. It requires a 10BASE-T/100BASE-TX shielded twisted-pair (STP) cable.

- Turn off the power switch.

- Loop the network cable and attach the ferrite core.

Note

- The network cable loop should be about 5 cm (2") from the end of the cable (on the end closest to the printer). The ferrite core at the end of the cable should be a ring type ferrite core.

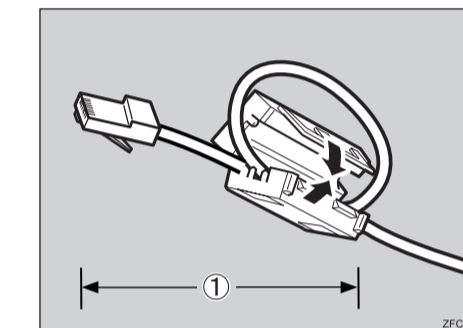

- Attach the network cable to the network cable connector of the printer. Secure the cable.

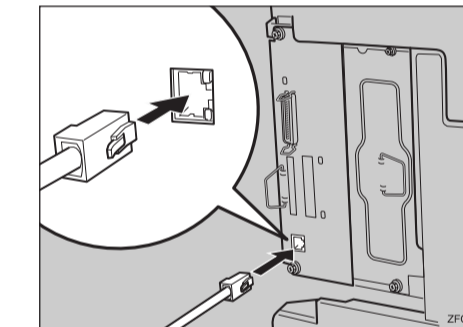

- Connect the other side of the cable to the network. Secure the cable.

- Turn on the power switch.

Check the LEDs on the ethernet port.

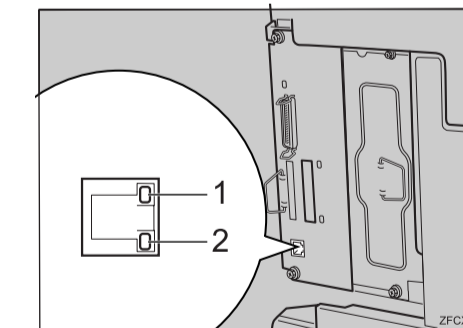

1 is lit when the printer is securely connected to the network.

2 is lit when 100BASE-TX is in use and not lit when 10BASE-T is in use.

B

Connecting the Printer to a Computer

Important

- The parallel cable is not provided with the printer. It is your responsibility to provide the parallel cable appropriate for the computer that you are using.
- The printer's parallel connection is a standard bi-directional interface. It requires a standard 36-pin parallel cable compliant with IEEE 1284 and an available parallel interface connector on the computer.
- To avoid electrical interface, use a shielded cable.

Note

- Do not use a parallel cable longer than 2.5 meters (8.2 feet).

- Turn off the power switch.

- Turn off the computer.

- Attach the parallel cable to the parallel interface connector on the left side of the printer. Secure the cable with the metal fittings as shown in the illustration.

Important

- The rating voltage of the parallel port for the computer is: DC 5V.

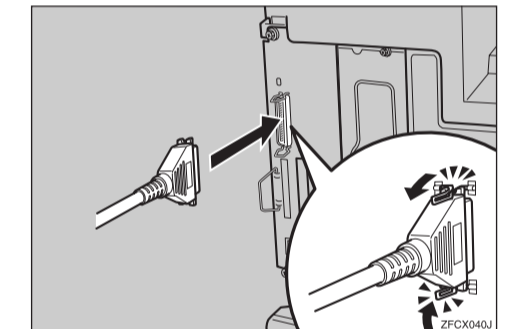

- Attach the other end of the parallel cable to the parallel interface connector of the computer. Secure the cable.

9

SETTING UP FOR PRINTING

Printing requires installation of a printer driver for your operating system.

Reference

- See "Printer Drivers for Your Printer" in the Setup Guide.
- To install options, see "Installing Options" in the Setup Guide.